

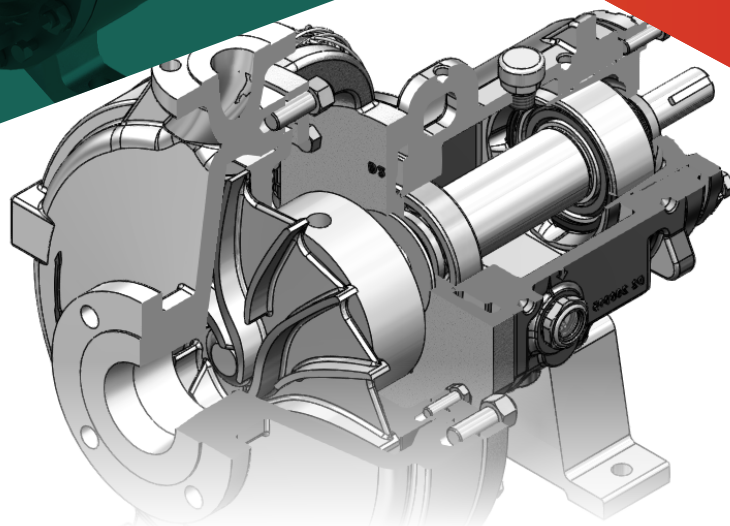

Dura Pump

D- Series Conform to the ANSI/ASME B73.1 standard

STANDARD PUMP | LOW FLOW PUMP | SELF PRIMING

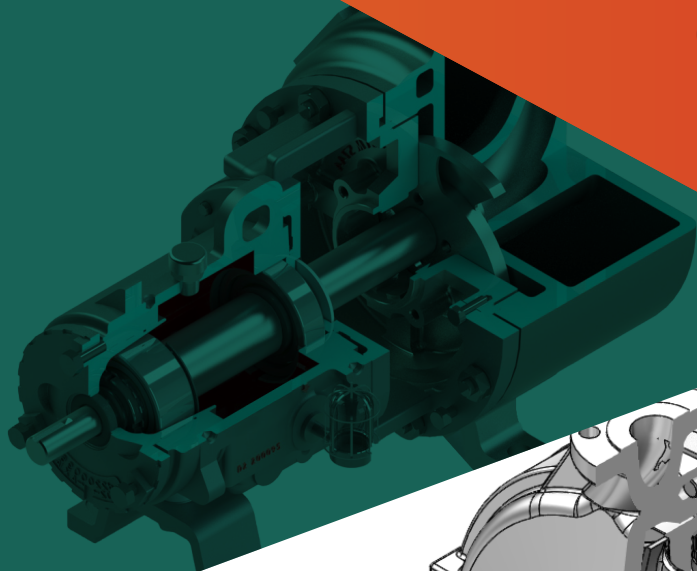
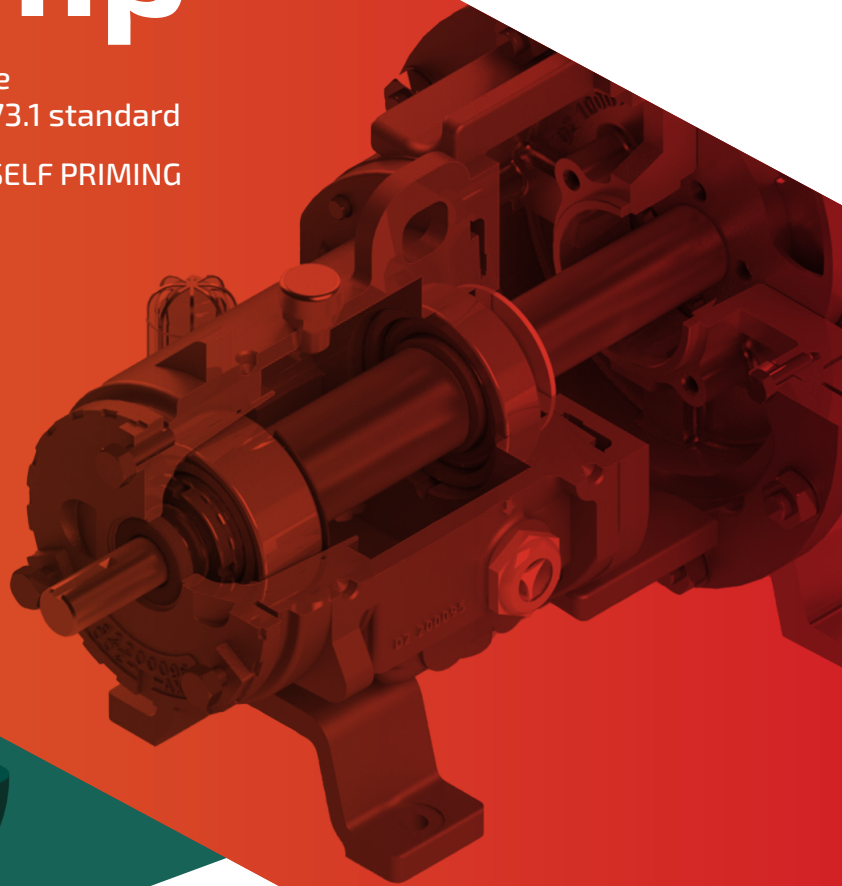

APPLICATIONS: Chemical Industry, Petrochemical Industry, Pulp & Paper Industry, Oil & Gas Industry, Power Plant Industry, Mining Industry, And other process industries

Dura Standard Pump

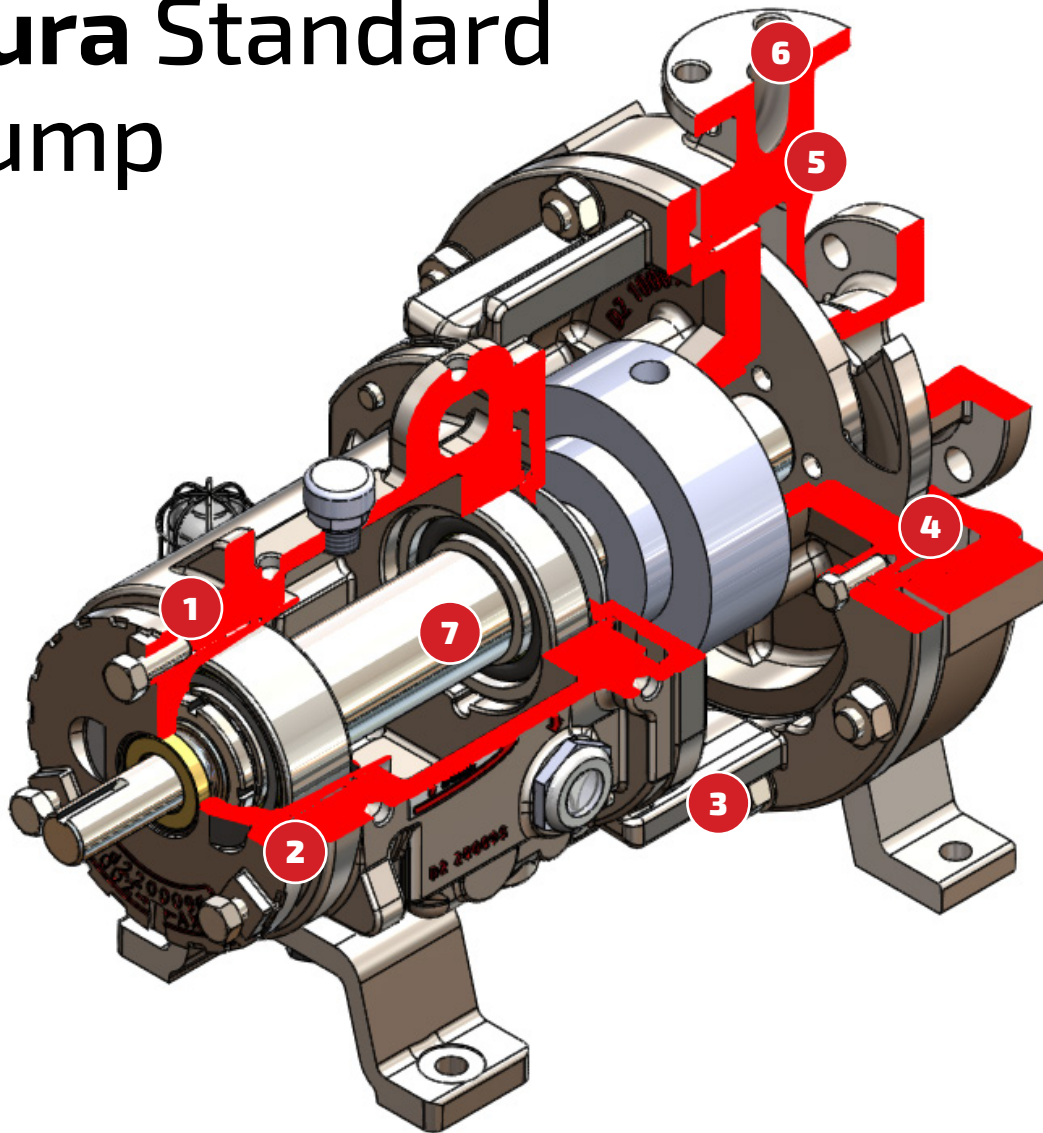

Design Features

ASME / ANSI B73.1 Standard: To ensure dimensional interchangeability with other pumps of the same standard.

True Back pull-out design: Allows you to remove all rotating elements without disturbing the casing, piping or motor.

Reverse Vane Impeller: Offers repeatable pump performance (back to the original performance) throughout the life of the pump, lowest NPSHr, low & predictable seal chamber pressure, low cost rear cover plate rather than casing, in-shop impeller setting without casing.

Open Impeller (Optional): Fully interchangeable with the reverse vane impeller. Excellent choice for stringy or fibrous application.

Widest Hydraulic Coverage in the process industry: Capacities to 7400 gpm (1682 m³/hr) @ 60 hz or to 6120 gpm (1391 m³/hr) @ 50 hz. Heads to 985 ft (300 m) @ 60 hz or 655 ft (200 m) @ 50 hz.

Maximum Pump Parts interchangeability: Three (3) rugged power ends for all 38 pump sizes, reduce spare parts inventory cost.

1. Heavy Duty Power Ends

Three rugged power ends for all 38 sizes reduce spare parts inventories. DURA³⁺ power end (optional) featuring Inpro/seal (shown here) bearing isolators with a full 3 years warranty.

2. Micrometer Impeller Adjuster

- Impeller to rear cover plate clearance adjusted by hand in 20 seconds without feeler gauges.
- Impeller setting done very easily, fast and accurate.

3. True Back-Pull Out Design

Allows you to remove all rotating elements without disturbing the casing, piping or motor.

4. Reverse Vane Impeller

- High efficiency
- Lowest NPSH requirement
- Low & repeatable seal chamber pressure
- Low cost rear cover is wear surface rather than the casing
- Repeatable performance assurance
- In-shop impeller setting without casing

5. Casing

Top centerline discharge, self-venting

6. Flanges

ANSI standard flanges 150# or 300#, flat or raised face

7. Heavy Duty Shaft

Shaft designed for minimum deflection, less than 0,002 inch (0,05 mm) at seal faces

Heavy Duty Power end: Rugged design, low shaft deflection, extends mechanical seal & bearings life. Dura power end featuring inpro/seal provides full three (3) years warranty.

Double bearings: Dependent on suction pressure or thrust load, either double row or duplex angular contact (optional) bearings are provided for extended service life.

External micrometer impeller adjuster: impeller to rear cover plate clearance is easily, accurately and quickly adjusted by hand, using the micrometer impeller adjuster. Proper clearance maintains the efficiency of the pump, lowering power usage and electricity costs. No shims, jackbolts or feeler gauges are required for setting the impeller.

Available in wide range of alloys: Ductile iron, Carbon Steel, 316 SS, Duplex SS, Super Duplex SS, Alloy 20, Nickel, Hastelloy B, Hastelloy C, Titanium, Zirconium, other materials may be available upon request.

Water cooled bearing housing (optional): Lower temperature in bearing housing and increase bearing life.

Steam Jacketed casing (optional): Allows pumping liquid to be held at constant temperature. Cuts maintenance and repair costs

Centerline mounting casing (optional): May be used to reduce loads caused by thermal expansion.

Dura Low Flow Pump

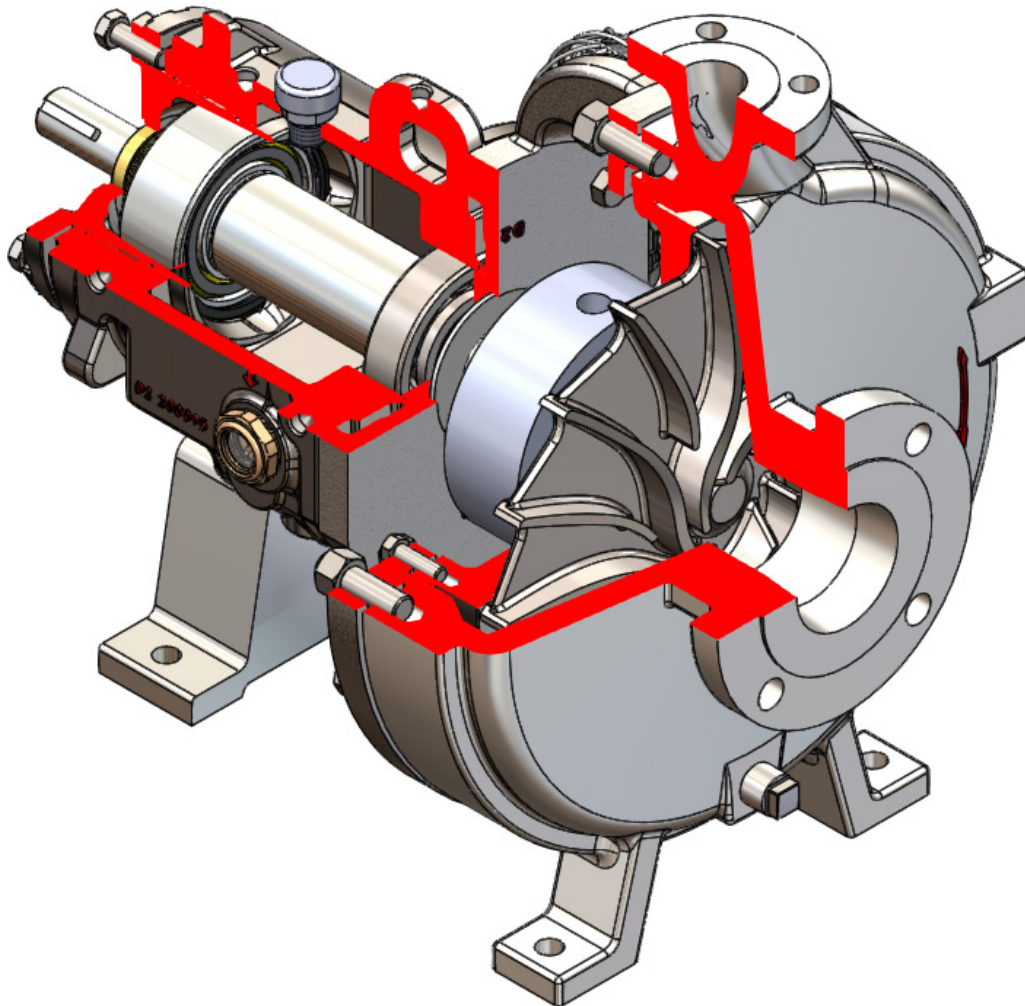

Design Features

- Pump can reliably produce a high head (985 ft)
- Unbalance forces are minimized
- Radial loads are reduced by up to 90%
- Bearing life is extended
- Shaft deflection is reduced
- Mechanical seal life is extended
- Shaft vibration is reduced by up to 50%
- Lower NPSHr
- Only casing and impeller are special
- All other parts are same as Standard pump
- Pump can be reliably used at low flows, provided flow exceeds minimum thermal flow
- Hydraulic force does not have to be considered
- Maximum pressure is 450 psig
- Maximum temperature is 700 deg F
- Centerline mounting of casing is available
- Casing jacketing is available
- All dimensions confirm to ANSI/ASME B73.1

Dura Low Flow PUMP is specifically designed to provide superior performance for low flow services of the Chemical Process Industries

Many conventional pump users throttle pumps to attain desired low flow performance. Because conventional (expanding volute) pumps are not designed to operate continuously in this range, the resultant higher radial loads and increased shaft deflection lead to premature bearing and mechanical seal failure. Unscheduled downtime and higher maintenance costs are the consequence.

Many conventional pump users put a bypass line from the pump discharge line back to the suction source. This is to protect the pump from running below the minimum flow. But, this bypass system is inefficient and very costly in the long run because the additional power costs to run the pump driver is higher than normally realized.

The Dura Low Flow Pump is the best solution for the above application, more reliable and more economical at low flow services.



Standard Pump

Expanding volute casing

Design to run at BEP

At low flow :

- High radial loads
- High static deflection
- High dynamic deflection



Low Flow Pump

Circular, concentric casing

Design to run at low flow

At low flow :

- Low radial loads
- Low static deflection
- Low dynamic deflection

Other Dura Pump Product

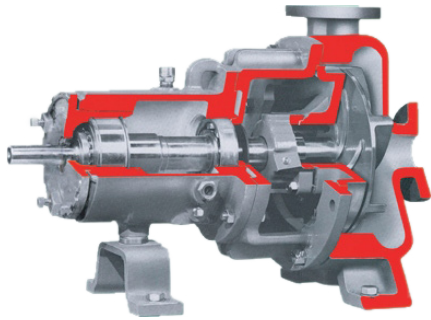

Vortex Pumps

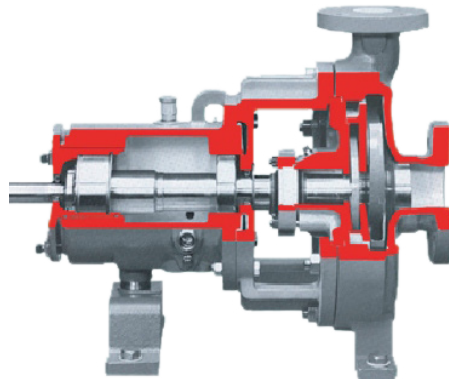

Dynamic Sealing Pumps

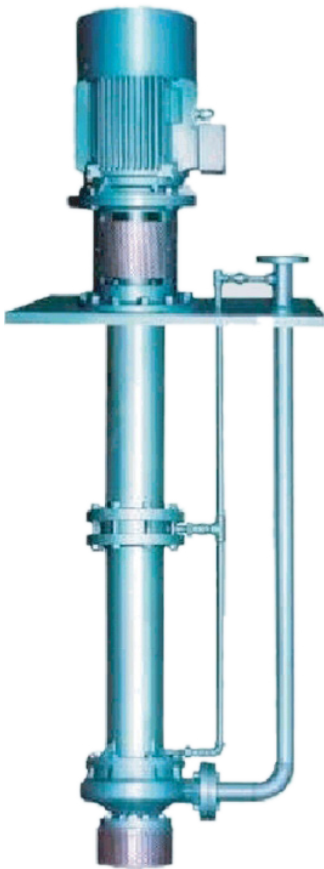

Vertical Sump
Pumps/VS4

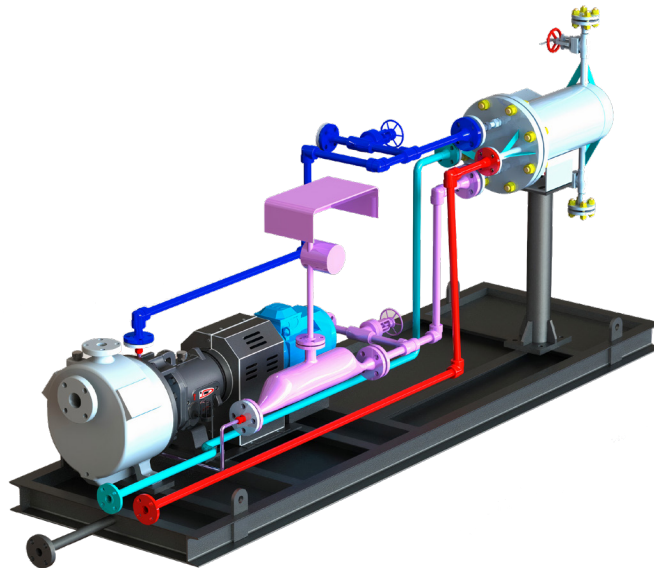

Submersible
Pumps



Performance Range

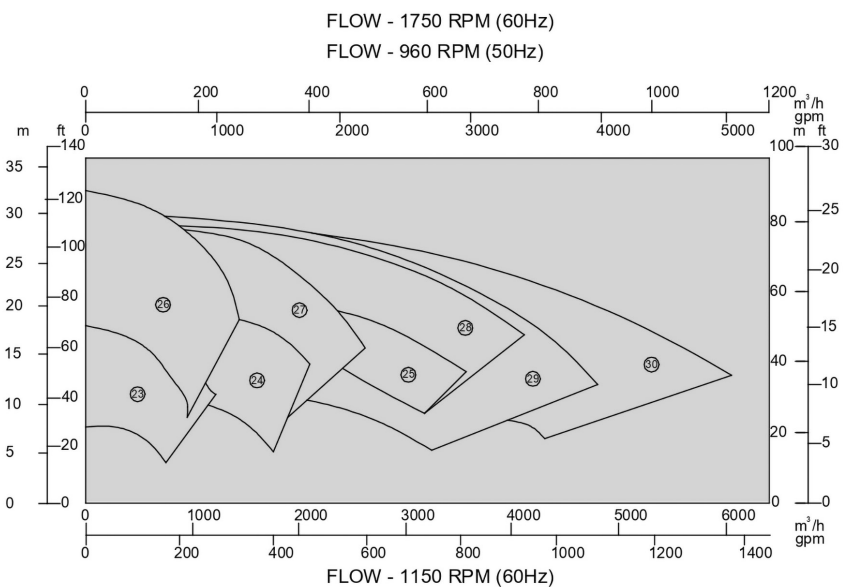
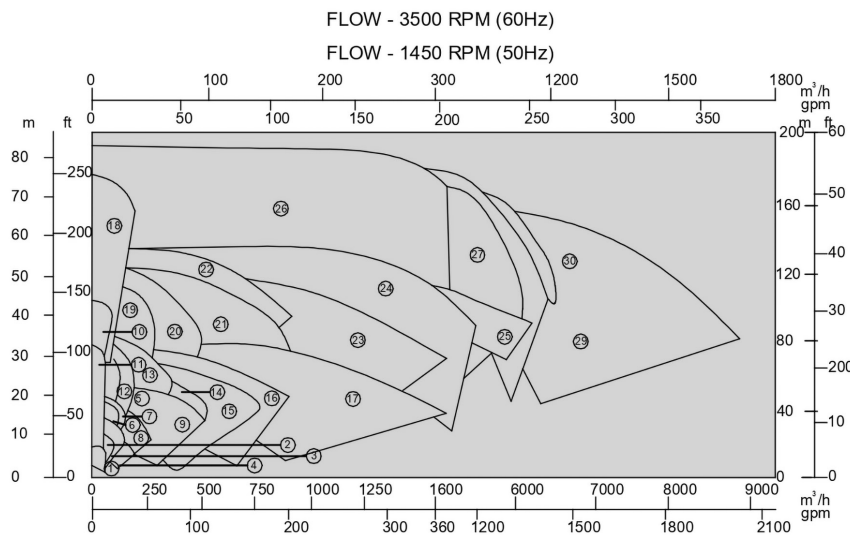
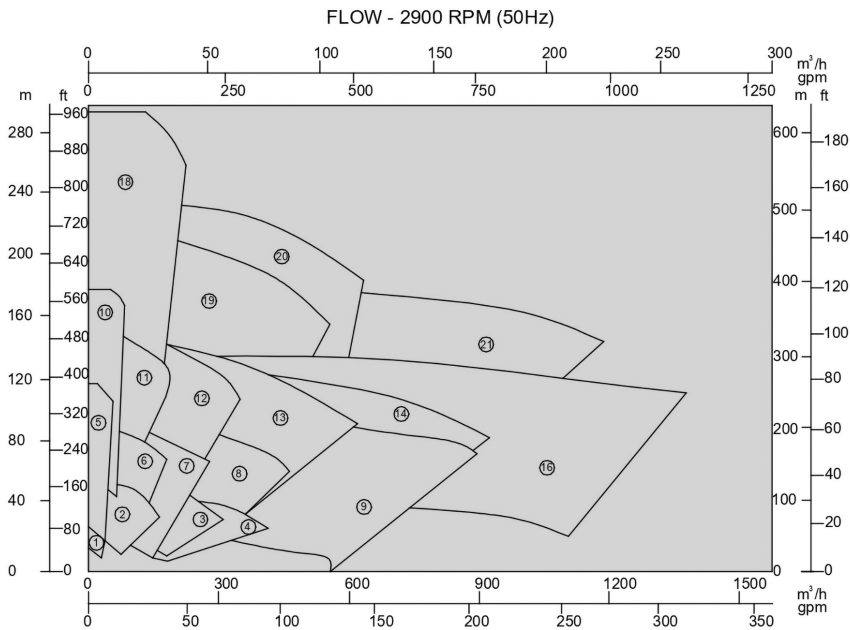

Group I

1. D11.5 X 1LF - 4
2. D11.5 X 1 - 6
3. D13 X 1.5 - 6
4. D13 X 2 - 6
5. D11.5 X 1LF - 8
6. D11.5 X 1 - 8
7. D13 X 1.5 - 8

Group II

8. D2 3 X 2 - 8
9. D2 4 X 3 - 8
10. D2 2 X 1LF - 10
11. D2 2 X 1 - 10
12. D2 3 X 1.5 - 10
13. D2 3 X 2 - 10
14. D2 4 X 3 - 10
15. D2 4 X 3 - 10H
16. D2 6 X 4 - 10
17. D2 6 X 4 - 10H
18. D2 3 X 1.5LF - 13
19. D2 3 X 1.5 - 13
20. D2 3 X 2 - 13
21. D2 4 X 3 - 13
22. D2 4 X 3 - 13H
23. D2 6 X 4 - 13

Group III

24. D3 8 X 6 - 14
25. D3 10 X 8 - 14
26. D3 6 X 4 - 16
27. D3 8 X 6 - 16
28. D3 10 X 8 - 16
29. D3 10 X 8 - 16H
30. D3 10 X 8 - 17

Dura Self Priming Pump

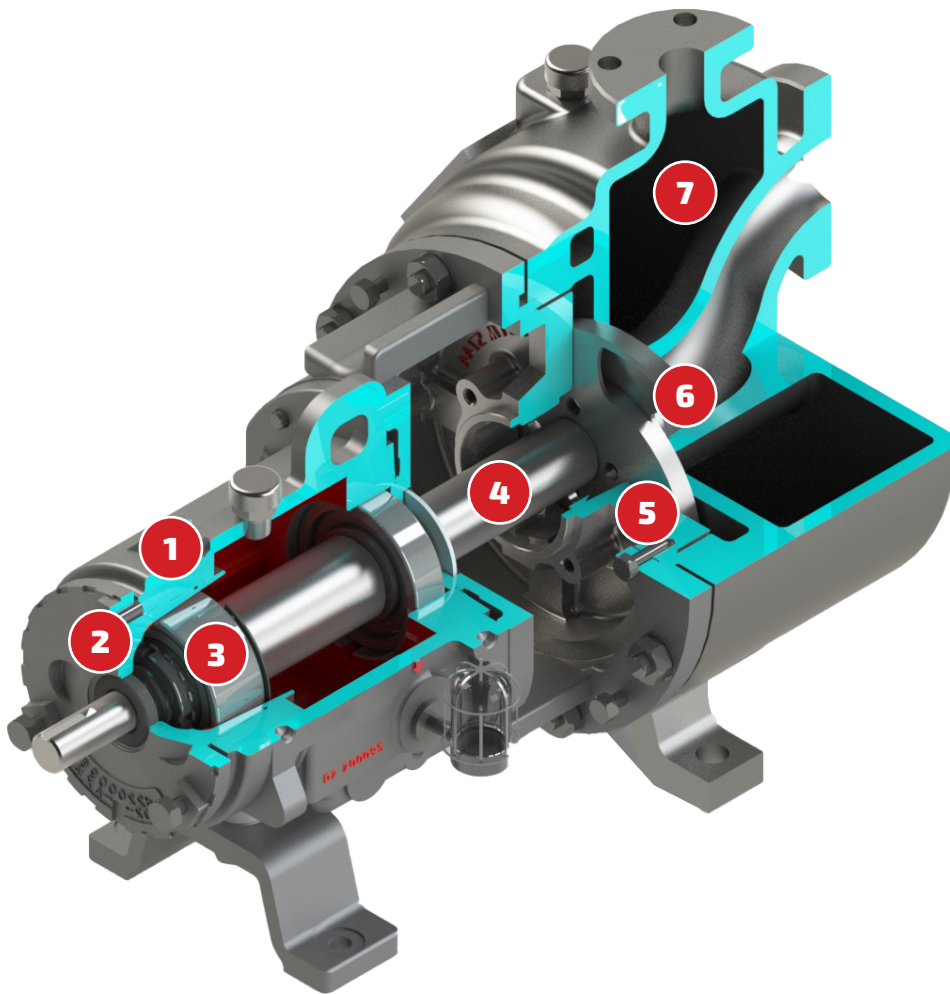

- 1. Standard power ends**
- 2. External micrometer impeller adjuster**
- 3. Double row outboard bearing**
- 4. Shaft deflection less than 0.002"**
- 5. Oversized seal chamber, optional**
- 6. Reverse vane impeller**
- 7. Large volume priming chamber**

Eight Sizes

- D1 1.5 X 1 SP - 6
- D1 1.5 X 1.5 SP - 8
- D2 2 X 1.5 SP - 10
- D2 3 X 2 SP - 10
- D2 4 X 3 SP - 10
- D2 3 X 2 SP - 13
- D2 4 X 3 SP - 13
- D2 6 X 4 SP - 13

Capacities

- To 1400 gpm (320m³/hr) @ 60 hz
- To 1170 gpm (266m³/hr) @ 50 hz

Heads

- To 400 ft (122m) @ 60 hz
- To 280 ft (85m) @ 50 hz

Static Suction lift

- To 20 ft (6.1 m)

Materials

- Carbon Steel, A 216 Gr. WCB
- 316 Stainless Steel, CF - 8 M
- Duplex SS, CD - 4 MCu
- Alloy 20, CN - 7 M
- Hastelloy C
- Additional materials on request

Wide Range of Seal Chamber Choices

- Oversized seal chambers
- Conventional stuffing boxes for mechanical seals or packing.

Heavy Duty Power End

- External Micrometer impeller adjuster
- Maximum parts interchangeability
- Reduced maintenance costs
- Lower inventory costs.

Dura Self Priming Pumps vs Vertical (Sump) Pumps

- Located at ground level - high, dry
- Installation is simple
- Maintenance is easily performed
- Lower installation cost
- Can be mounted on a trailer for movement to various pumping location
- Short shaft overhung
- Less expensive than Vertical (Sump) Pump
- All the spare parts are interchangeable with the Dura standard pump, except the casing only

Priming Cycle Cutaway Illustrations

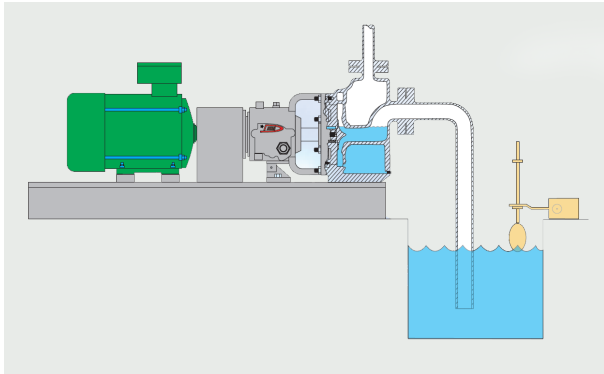

1. Sump Filling, Pump Stopped

For good self-priming operation the casing contains a sufficient volume of priming liquid necessary to entrain the air contained in the suction line.

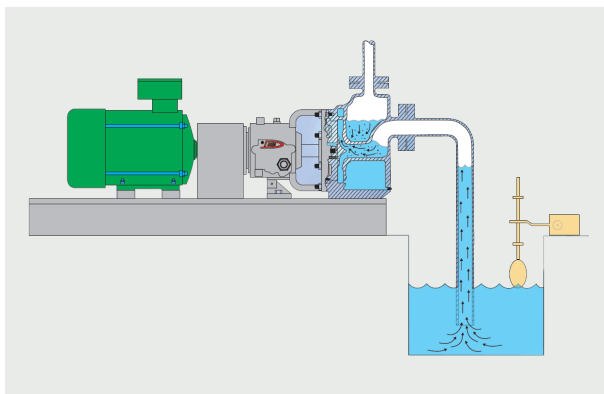

2. Pump Start-Up

As the impeller spins, the priming liquid entrains air from the suction pipe and is pumped into the air separator/priming tank portion of the casing. The air vents out the discharge while the priming liquid flows through the bypass slot in the bottom of the casing and back into the impeller eye.

As the priming liquid circulates, it re-entrains more air, creating a partial vacuum in the suction line. The sump liquid is then pushed upward by atmospheric pressure

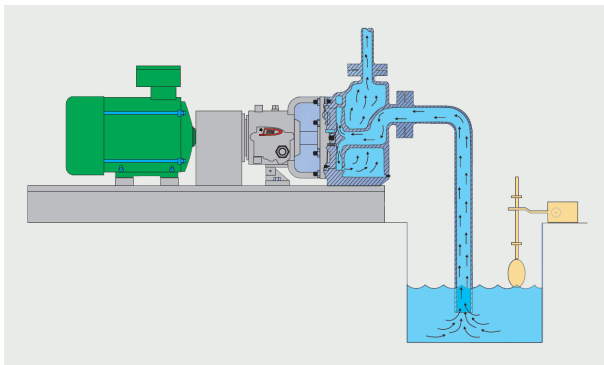

3. Priming Achievement

After the priming cycle has evacuated all of the air from the suction pipe, the sump liquid fills the volute, air separator and priming chamber, and pumping out of the discharge pipe begins.

The Self - Primer is fully primed and now operates exactly as a standard flooded - suction Dura pump

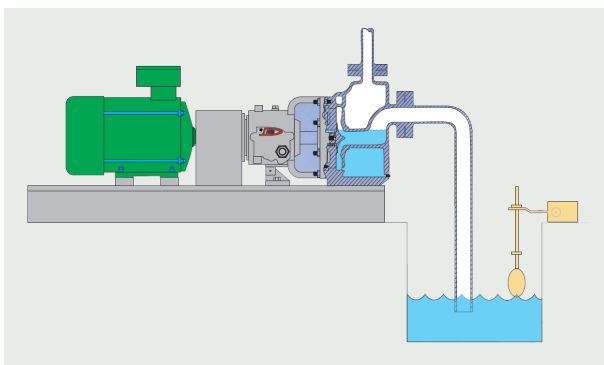

4. Sump Empty, Pump Stopped

When the pump stops, the liquid in the discharge piping flows back through the pump, leaving the priming chamber filled with sufficient liquid for the next priming cycle. Except for the first fill-up of the priming chamber and an occasional "topping off" in dry climates, the Dura Self-Primer is automatic and trouble-free

Your Best Choice for :

Industrial Sumps, Waste Treatment Pond Transfer, Tank Car Unloading, Mine Dewatering, Chemical Transfer, Petroleum Transfer, Aircraft Fueling, Lift Station Applications

Dura Pump D Series Interchangeability

Group I

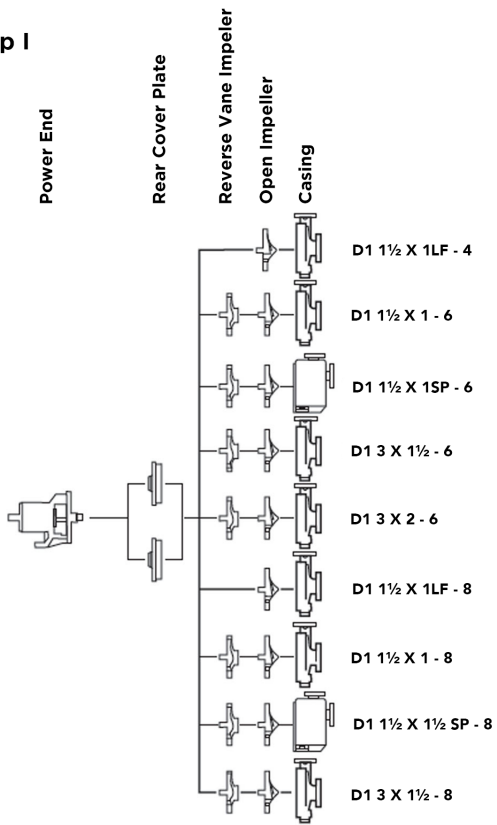

Group II

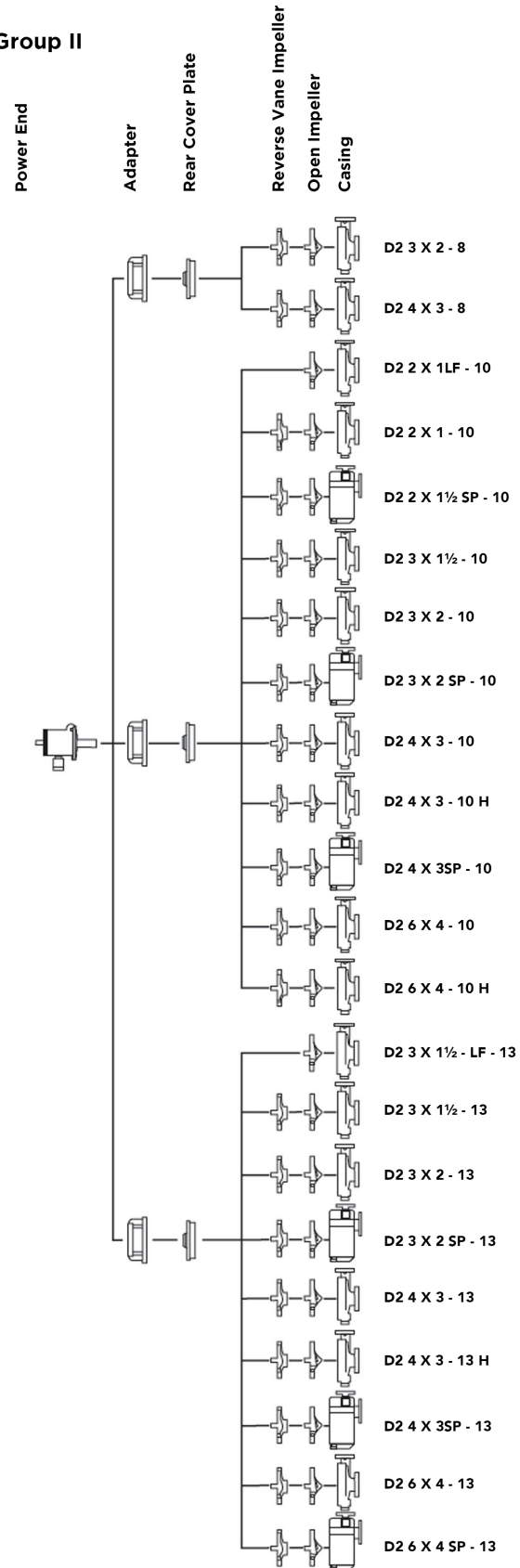

Group III

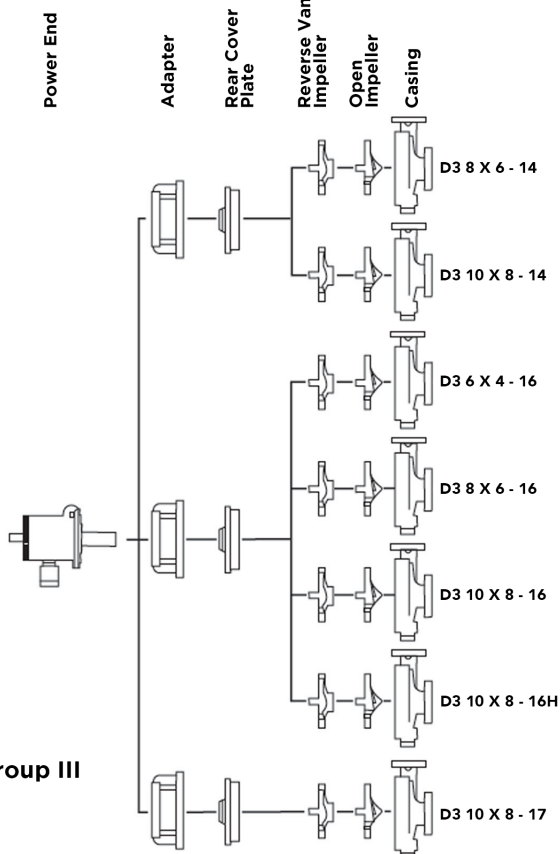



PT DURAQUIPT CEMERLANG
Head Office and Factory

Jalan Limo Raya No. 9, Limo,
Depok - 16515,
Jawa Barat - INDONESIA
Phone: +62-21-753 5559
Fax: +62-21-753 6031
Email: e-marketing@ptdq.com
Website: www.ptdq.com